

**HÄFELE**  
APPLIANCES

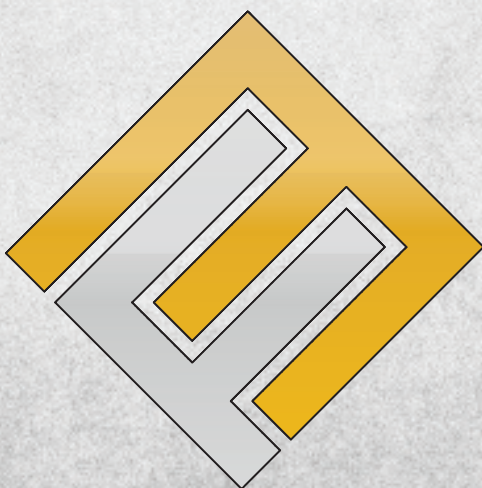

**Series**



# OVER 97 YEARS OF PROFESSIONAL EXPERIENCE IN CREATING LIFESTYLE



*“For over 9 decades, we’ve been helping people make more of their homes.*”

Established in Germany, and now operating worldwide, we specialise in the fittings, hardware and systems that improve the way your home, works. So when you choose our products as part of your new or reformed home, you know you’re getting the benefit of extensive knowledge and decades of experience.

And we’re still a family business, owned and managed by family members who really care about the products and service we provide. You can rely on our commitment to the highest standards of quality and reliability, founded on a long tradition of German engineering where attention to detail is second nature.

*All our home improvement ideas are built to last – day in, day out – we want you to get the very best from every corner of your home, for many years to come.”*

# OUR PRESENCE



**Hafele Worldwide:** With its origin in 1923 in a small town named 'Nagold' from the Swabian region of Germany that nurses a passion for hardware technology, it is no surprise that Hafele has lived up to its roots through a successful presence in the architectural and furniture hardware industry for over 9 decades now. Today, Hafele's worldwide penetration includes 38 subsidiaries across Europe, America, Asia, Australia and New Zealand. With these subsidiaries and numerous other sales organisations, Hafele operates in over 150 countries. The Hafele headquarters, 4 manufacturing units and 10 sales offices are located within Germany; while 1 manufacturing unit is located at Budapest, Hungary. The company also owns one of the largest and most sophisticated warehouses in its home country. The Hafele worldwide workforce is empowered by a base of over 8100 employees. The group services over 150,000 customers across the globe through its extensive range of hardware products and a comprehensive logistics system.

**Hafele India:** Hafele India is a wholly-owned subsidiary of the Hafele Global network and has been operating in India since 2003 under the leadership of Mr. Jürgen Wolf (Managing Director). The ability of the company to understand the diverse Indian market has made it an authority in the field of architectural hardware, furniture and kitchen fittings and accessories. The company also has a strong presence in synergized product categories namely Home Appliances, Furniture Lighting, Sanitary and Surfaces catering to the focused demand from these industries.

Hafele India services its customers with a base of over 1300 employees and has a strong nation-wide presence with offices in Mumbai, Pune, Ahmedabad, Bangalore, Chennai, Hyderabad, Delhi, Kolkata and Cochin. It has full-scale operations in Sri Lanka and Bangladesh with Regional offices and Design Showrooms in both the countries; and has also spread its operations to other regions of South Asia including Nepal, Bhutan and Maldives. It has a well-networked Franchise base of over 130 shops along with over 1000 dealers situated across South Asia. The subsidiary has a sophisticated Logistics centre in Mumbai along with distribution centres in Delhi, Bangalore, Kolkata and Colombo respectively.



# HAFELE FM SERIES



Our latest range of appliances - “Hafele FM Series”, is designed for the modern contemporary kitchens in India. These appliances are backed by the excellence of German Design and Engineering, specially adapted for Indian kitchen environments and the unique styles of Indian cooking. FM series appliances follows a simplistic philosophy; highly Functional appliances in Modern designs.

We offer you a wide range of appliances under FM range – Filter-free hoods, for a hassle-free and low maintenance kitchen, heavy duty brass burner hobs equipped with safety features, modern built in ovens and microwaves and designer chimneys that will cater to all your cooking requirements.



# DESIGNED TO CREATE EXPERIENCES... OUT OF DAILY CHORES!



Built in Gas Hobs



Cooker Hoods



Oven & Microwave



Built-in & Freestanding Dishwashers



# MAGNA PLUS SERIES HOBS

## POWER, EFFICIENCY AND DURABILITY

The Magna Plus Series hobs consists of powerful brass burners with different power variations that aid in a faster and efficient cooking experience.

Unlike the conventional hob design the Magna Plus hobs are sleek, easy to handle while cooking and very easy to maintain.



The special design **triple flame brass burners** are extremely powerful with an output of over 4 kW of power.



The **FFSD** (flame failure safety device), on all burners, shuts the gas supply in case the flame goes off accidentally.



The Premium **soft touch knobs** with seamless movement help to control the flame output as per the requirement of the user.



Press and turn the knob and the **auto ignition** will get activated. No need of a lighter to ignite the hob.

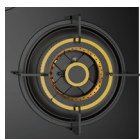

The **SPCD Steel drip tray** avoids spillage and is very easy to clean.



The Contemporary **flat metal pan support** design allows better stability.

## ONE BIG STEP TOWARDS SAFETY

---



The FFSD activates the moment the gas burner flame goes off and automatically cuts off the gas supply to the burners thus preventing any instance of gas leakage. The result – your kitchen and home is safe from any kind of gas leakage accidents.

Once the thermocouple comes in contact with heat (generated through the lit flame) it controls the gas valve through the FFSD valve and the coil, which in turn compresses the spring within the valve and generates gas supply.

In case the flame goes off accidentally, the thermocouple cools down and releases the spring within the FFSD valve, thereby cutting off the gas supply to the burner. This process secures your appliance and kitchen environment from any gas leakage.

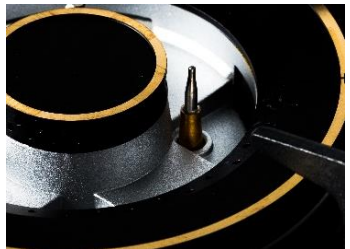



**Magna Plus 480**  
80cm 4 burner Built in Hob  
Article: 538.41.506



**Magna Plus 460**  
60cm 4 burner Built in Hob  
Article: 538.41.531



**Magna Plus 378**  
78cm 3 burner Built in Hob  
Article: 538.41.505



## BUILT-IN HOBS



## SAY “NO” TO FUMES AND UNWANTED ODOUR !

---

Hafele’s HIGHLY EFFICIENT AND STYLISH range of cooker hoods free your kitchen from unwanted and unhealthy cooking smoke and residues; all that is left to sniff is the welcoming fragrance of appetizing delicacies!

### **Nebel Nero Series**

Anthracite T-Shape Hood Range with Aluminium Mesh Filters available in 90 & 60 cm. These are mechanical control models.



#### **NEBEL NERO 90**

90cm Wall Mounted Hood with  
3 Mesh Filters  
Article: 533.87.215

### **Curve Plus Series**

Curve Glass Range of hood with Mesh filters and timeless design. Digital display and LED lighting makes it a centerpiece of the kitchen.



#### **NEBEL NERO 60**

60cm Wall Mounted Hood  
with 2 Mesh Filters  
Article: 533.87.213

## WALL MOUNTED HOODS

---



## CURVE X SERIES - DESIGNER HOOD

---



**Digital Display** with Timer function



Modern and Efficient **Strip LED lighting** for better illumination



**Powerful Motor** enables the hood to exhaust high volume of smoke out of kitchen.



**Wider suction panel** with 3 filters in 90cm and 2 filters in 60cm model





**CURVE 60X**

60cm Wall Mounted Hood with  
2 Baffle Filters, Touch Control  
Article: 533.87.512



**Curve 90X**

90cm Wall Mounted Hood with 3  
Baffle Filters, Touch Control  
Article: 533.87.524



**NEBEL INOX 60**

60cm Wall Mounted Hood  
with 2 Mesh Filters  
Article: 533.87.214



**NEBEL INOX 90**

90cm Wall Mounted Hood with 3  
Mesh Filters  
Article: 533.87.212



## FILTERFREE COOKERHOODS

---



### Leo 90 PLUS

90cm Wall Mounted

Filter-free Hood

Article: 538.81.544



### CRV 60 PLUS

60cm Wall Mounted

Filter-Free Hood

Article: 538.81.561



### LEO 90

90cm Filter-free Hood

Article: 533.83.604



### LEO 60

60cm Filter-free Hood

Article: 533.83.632



Nautilus Design for the most efficient filterfree ventilation in your kitchen



96% Filtration efficiency that separates smoke and grease to keep the kitchen clean from unwanted grease and smell



One touch control for easy operation of hood



3 speed control for light to heavy cooking in the kitchen



Delayed stop function that will automatically switch off the hood in 5 mins after activation



Bright & efficient dual LED strip light for a well illuminated cooking counter

## WALL MOUNTED HOODS

---

# BUILT IN OVEN & MICROWAVE

---





# FEATURES

---



MULTIPLE MODES



ROAST



GRILL



MICROWAVE



DEFROST



BAKE



### FM65BIO

Built in Oven  
65L Capacity  
Mechanical timer up to 120 mins  
7 cooking functions  
50°C to 250°C  
Double Glazed Door  
Article: 538.01.271



### Celia 70

60 cm Built in Oven  
70L Capacity,  
Electronic Knob  
9 Cooking Functions + 2  
Additional function (Rotisserie &  
Food Probe)  
3 Layer Glass Door  
Removable door plate  
Article: 538.01.311

## BUILT IN OVEN







### **FM20MWO**

Built in Microwave

20L Capacity

Timer Knob Program Knob

5 power levels Grill + Microwave

Article: 538.31.300



### **AIDA 28**

Built in Microwave

28L Capacity

Easy Button Operation Program Knob

5 power levels Grill+Microwave

Article: 539.30.190

**BUILT IN MICROWAVE**

---



# DISHWASHERS

---



## FEATURES

---



### **Active Clean Technology:**

The Hafele Dishwashers delivers a hygienic wash capable of eliminating 99.9% germs and bacteria. The high temperature (70°C) inside the dishwasher accompanied with the water pressure removes all the sticky residue, bacteria and germs.



### **Steel for a Stainless wash!:**

Complete marine grade Stainless Steel inner drum for long lasting performance

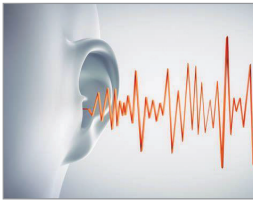

### **Quieter Wash Cycles:**

The sound reducing material, massive insulation, quality of components and the science of hydraulics integrated within the Dishwashers ensure silent washing and drying cycles. 49dBA noise level at max. is what you can expect from a Hafele dishwasher.



### **Height Adjustable Rack:**

The Adjustable racking system can make way for crockeries of different shapes and sizes.



### **No More Wet Utensils:**

Hafele Dishwashers offer the feature of integrated fan assisted drying with the wash cycles.



### **Delayed Start Program:**

Don't want your dishes to be washed and kept in the dishwasher for a long time before you arrive home? The delayed start function helps you to set the time at which you want your washing to begin. You can choose to delay the time of the wash program by 3/6/9 hours accordingly.



## PROGRAMS

---



### **Intensive**

Designed for highly soiled wash loads, such as pots, plates and woks.

Cycle: Pre-wash (50°C) - Wash (60°C) - 3x Rinse (70°C)  
- Dry



### **Normal**

For high-medium soiled utensils. Ideal for daily wash of a load of utensils used for regular cooking

Cycle: Pre-wash (45°C) - Wash (55°C) - 2x Rinse (65°C)  
- Dry



### **90mins Wash**

For medium soiled mixed loads that do not need excellent drying efficiency.

Cycle: Wash (65°C) - 2x Rinse (65°C) - Dry



### **ECO:**

Most economical washing program for medium soiled daily dishes that are kept waiting.

Cycle: Wash (45°C) - Rinse (65°C) - Dry



### **Rapid 30**

Suitable for lightly soiled daily dishes that are scraped or pre-cleaned.

Cycle: Wash (45°C) - Rinse (55°C)



### **Glass**

For delicate glassware like bowls, plates, wine glasses etc.

Cycle: Pre-wash (30°C) - Wash (40°C) - 2x Rinse (60°C)  
- Dry

## FREESTANDING DISHWASHER

---



### **AQUA 12S**

- Standard place settings: 12
- Material: Stainless Steel (Drum) and Mild Steel (Exterior Body)
- Finish: Silver Inox
- Energy consumption: 258 kWh
- Water consumption: 11 L/Cycle (ECO program)
- Energy efficiency class: A++
- Drying efficiency class: A
- Number of Spray Jets: 2
- Number of Baskets: 2
- Noise level: 49 dBA
- Installation Type: Freestanding

**Article no.: 539.20.550**



# INSTALLATION DRAWINGS

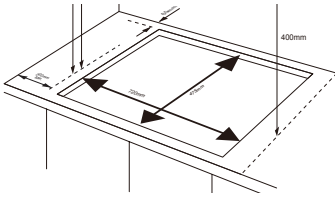

Magna Plus 480

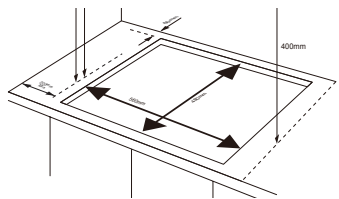

Magna Plus 460

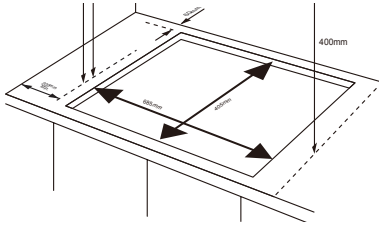

Magna Plus 378

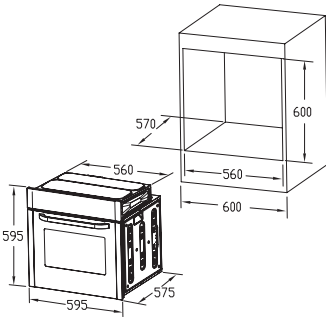

FM65BIO AND CELIA 70

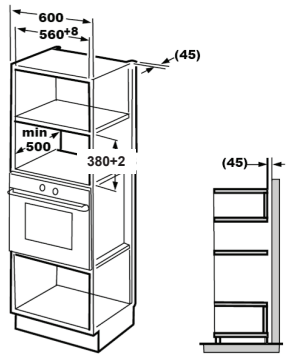

FM20MWO AND AIDA 28

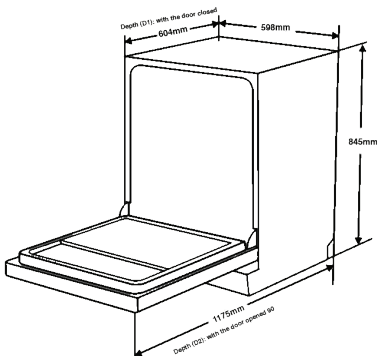

AQUA 12S



**Mumbai Design Centre:**

Haji Moosa Patrawala Ind.(SOBO)  
Estate, Near Famous Studio, Mahalaxmi  
(West), Mumbai - 400 011  
Tel.: 022 6264 7100.

**Mumbai Design Centre:**

#2 Filix Building, Opp. Asian Paints,  
L.B.S. Marg, Bhandup (West),  
Mumbai - 400 078  
Tel.: 022 2596 9660/  
2596 9787/2594 7305

**New Delhi Office & Design Centre:**

D-89 , 1<sup>st</sup> Floor, Okhla Phase-I,  
New Delhi - 110 020  
Tel.: 011-66574999  
Fax: 011-41605482

**Bangalore Office & Design Centre:**

Incubex Nestavera Spaces Pvt Ltd,  
No:13, Langford Place, Langford Road,  
Shanti Nagar, Bangalore - 560 025  
Tel.: 080 4132 6116  
Fax: 080 4132 6226

**Bangalore****Hafele Appliances Gallery:**

No. 2/1, Shiv Manor, Langford Road,  
Shantinagar, Bangalore - 560027  
Tel.: 080 - 4142 6336

**Hyderabad Office & Design Centre:**

SJR Building - # 1-57/89/1 & 1-57/89/2  
Opp Allahabad Bank, Gachibowli,  
Hyderabad - 500032  
Tel.: 040 29557578 / 040 29557588

**Kolkata Design Centre:**

PS PACE, Premises No. 1/1A,  
Mahendra Roy Lane, Topsia,  
Kolkata - 700 046  
Tel.: 033 40086814 / 033 40089268  
Fax: 033 24988020

**Kolkata Office:**

Office No. 1001, PS Continental,  
10<sup>th</sup> Floor, 83/2/1 Topsia Road,  
Near Vishwakarma Building.  
South Kolkata - 700046  
Tel: 033-2285 0104 /  
033-2285 0105 / 033-2285 0106

**Chennai Office & Design Centre:**

1<sup>st</sup> Floor No.24, College Road,  
Nungambakkam, Chennai - 600 006  
Tel.: 044 - 4215 1542  
Fax: 044 2446 0922

**Pune Design Centre:**

Showroom No. 2, Ground Floor,  
F P no. 403, A/2, ICC Trade Tower,  
Senapati Bapat Marg,  
Shivaji Nagar, Pune -411016  
Tel.: 020 2563 3301  
Fax: 020 2563 3302

**Pune Office:**

Office No. 12, Vastushree Complex,  
Survey No.587,  
Near Hyde Park, Gultekdi,  
Market Yard, Pune - 411 037  
Tel.: 020 2426 6264  
Fax: 020 2426 6274

**Ahmedabad Office:**

Hafele India Pvt. Ltd., Office No. 302,  
3<sup>rd</sup> Floor, Shangrila Arcade, Near  
Shyamal Cross Road, Satellite,  
Ahmedabad - 380015  
Tel.: +91 79695 55505 / 8866220505

**Cochin Office:**

Jomer Symphony, 5<sup>th</sup> Floor, 48/1744  
C34, Chalikkavattom, North Ponnuranni,  
Vytila, Cochin- 682010

**Sri Lanka:****Hafele Office and Design Centre:**

52, Nandana Gardens  
(On Duplication Road), Colombo 04.  
Tel: +94 112 500 501.  
Fax: 0094 112 500 553.

**Hafele Design Centre:**

448, Galle Road, Rawathawatta,  
Moratuwa, Sri Lanka.  
Tel.: +94 112 644 600.

**Hafele Boutique:**

747A, Sirimawo Bandaranayaka  
Mawatha, Mulgampola,  
Kandy, Sri Lanka.  
Tel.: +94 812 223 338.

**Bangladesh Office:**

2<sup>nd</sup> Floor, House - 181, Road - 2,  
Mohakhali DOHS, Dhaka - 1206.  
Tel.: 01844018431/ 01844018432/  
01844018433/ 01844018437.

**Bangladesh Design Center:**

House - 106, Road - 12,  
Block - E, Banani, Dhaka - 1213  
Tel.: 02-48810380-81

**Nepal:**

UHS Holdings Pvt. Ltd.  
Kathmandu-2, Gairidhara Chowk,  
Nepal.  
Mob.: +977 9802338800

**Bhutan:**

Smart Homes  
Gr. Floor, Druk Building (Opp Helipad)  
Babesa -Thimpu Expressway, Thimpu  
Tel.: +975-2-333419  
Mob.: +975-77277615, 17839717,  
77114228,1760063,17669840

# HAFELE

## Mumbai Corporate Office:

Office No. 3, Building "A", BETA,  
I Think Techno Campus, Off J.V.L.R.,  
Opp. Kanjurmarg East, Mumbai – 400 042.  
Tel.: 022 6142 6100 | Fax: 022 6702 0531.

## For Enquiries SMS

"HAFELE" to 56070

Toll Free Customer Care:

1800 266 6667

Customer Care WhatsApp:

+91 97691 11122

customercare@hafeleindia.com

info@hafeleindia.com

Follow us on

